



Fixed displacement bent axis piston pumps

for truck applications

DISPLACEMENTS

From 2.49 in³/rev
(40,9 cm³/rev)
To 6.71 in³/rev
(110 cm³/rev)

APPLICATION

High pressure

SECTOR

Mobil hydraulic

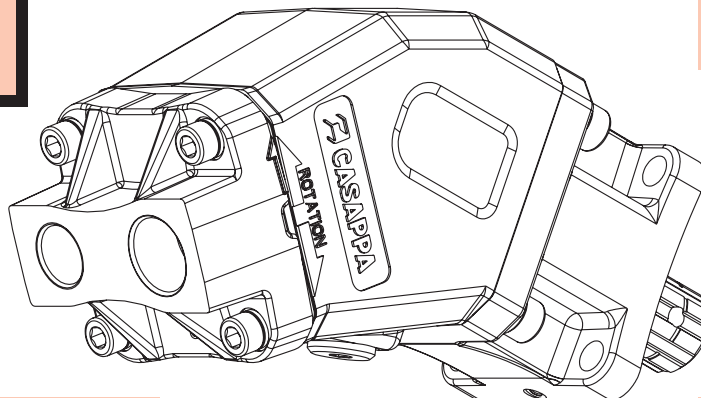

PRESSURE

Max. continuous 5075 psi (350 bar)
Max. peak 5800 psi (400 bar)

MAX. SPEED

2950 min⁻¹

- Low noise level
- Direct mounting on the PTOs
- Compact design
- High speed
- High volumetric, mechanical and overall efficiency
- Clockwise or anti-clockwise rotation turning the end cover 180°
- Standard ISO with Viton shaft seal

Pump type		● BAP32•40	BAP32•50	BAP32•63	BAP32•71	BAP32•80	BAP37•80	BAP37•110
Displacement	in ³ /rev (cm ³ /rev)	2.49 (40,9)	3.06 (50,1)	3.8 (63)	71.6 (4,37)	4.78 (78,3)	4.83 (79,1)	6.71 (110)
Max. pressure P _{max}	psi (bar)	continuous	5075 (350)	5075 (350)	5075 (350)	4568 (315)	4568 (315)	4350 (300)
		peak	5800 (400)	5800 (400)	5800 (400)	5075 (350)	5075 (350)	5800 (400)
Max. speed Inlet pressure 14.5 psi (1 bar abs.)	min ⁻¹	@ P _{max} cont.	1850	1700	1600	1300	1300	1300
		● without load	2950	2750	2450	2250	2200	2500
Mass	lbs (kg)	22.05 (10)	22.05 (10)	22.05 (10)	22.05 (10)	22.05 (10)	35.28 (16)	37.49 (17)

Fill with oil before start-up	
Direction of rotation (looking on drive shaft)	Clockwise or anti-clockwise rotation
Inlet pressure range	25 in Hg (0.85 bar abs.) ÷ 29 psi (2 bar abs.)
Operating temperature	176 °F (80 °C)
Fluid	Mineral oil based hydraulic fluids to DIN 51524
Viscosity range	From 58 SSU (10 cSt) to 1819 SUS (400 cSt) recommended 4546 SSU (1000 cSt) tolerated for cold starting
Filtering requirement	Cleanliness grade 8 according to class NAS 1638

Replaces: STN 01 T A
Modification from former edition

Edition: 01/04.2007



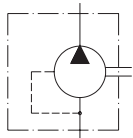
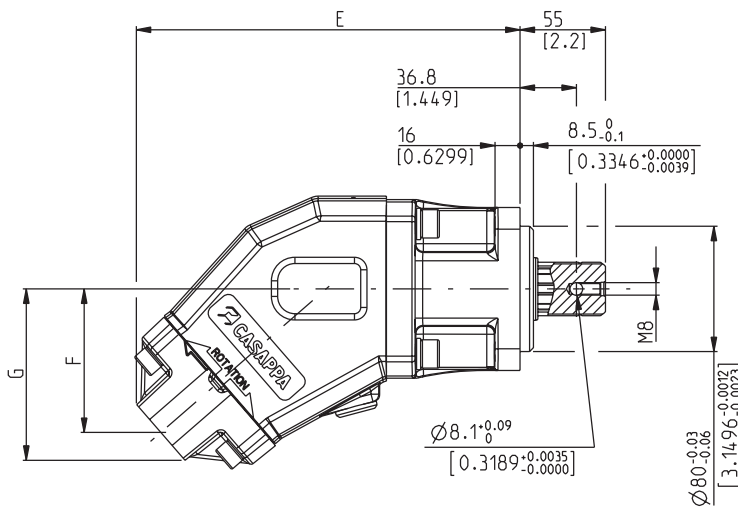
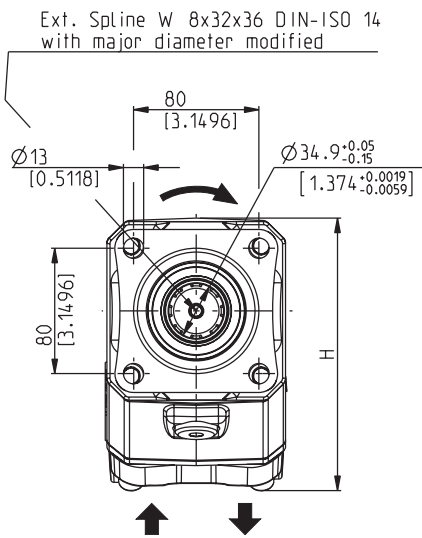
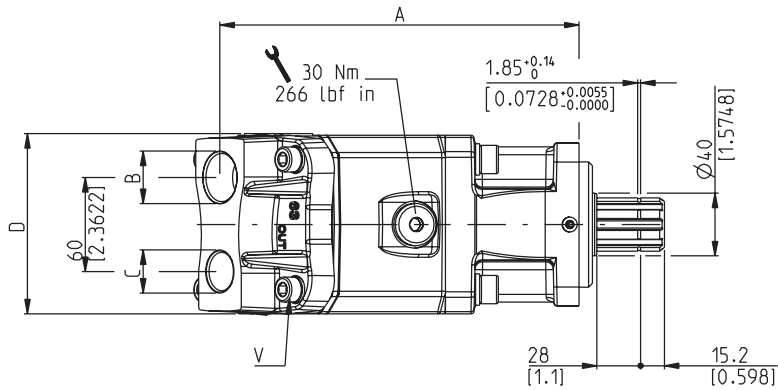
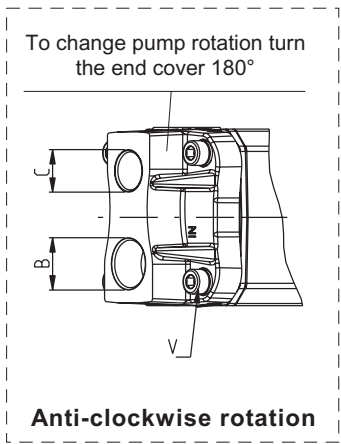

Pump type	V Bolts tightening torque lbf in (Nm)
BAP 32	358 ÷ 438 (45 ±4.5)
BAP 37	597 ÷ 730 (75 ±7.5)

Pump type	A	B (IN)	C (OUT)	D	E	F	G	H
		BSPP	BSPP					
	in (mm)	lbf in (Nm)	lbf in (Nm)	in (mm)	in (mm)	in (mm)	in (mm)	in (mm)
BAP 32•40	9.0157 (229)	G 1 620÷664 (70 ⁺⁵)	G 3/4 797÷841 (90 ⁺⁵)	4.5276 (115)	9.6457 (245)	3.5827 (91)	4.2913 (109)	6.8110 (173)
BAP 32•50								
BAP 32•63								
BAP 32•71								
BAP 32•80								
BAP 37•80								
BAP 37•110	9.8819 (251)	G 1 1/4 974÷1062 (110 ⁺¹⁰)	G 1 1328÷1460 (150 ⁺¹⁵)	5.0000 (127)	10.5512 (268)	4.2520 (108)	5.0394 (128)	7.9528 (202)

Rotation: S=anti-clockwise - D=clockwise

How to order

BAP 32•40 S0 - 16 Z0 - P GF/GE - N TN

Replaces: STN 01 T A

01/04.2007

Replaces: STN 01 T A

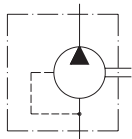
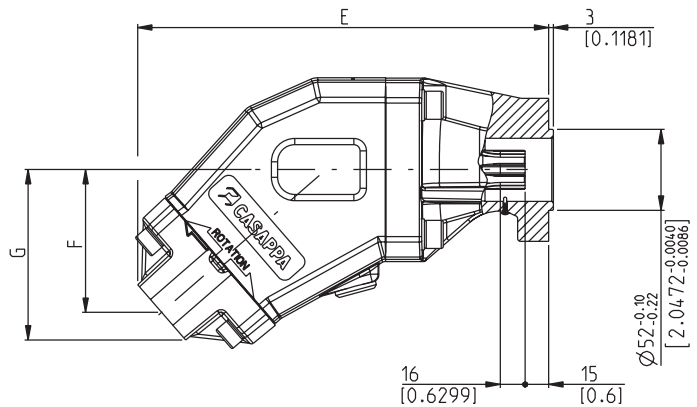
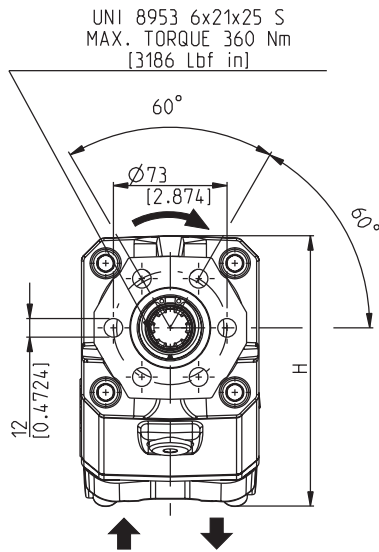
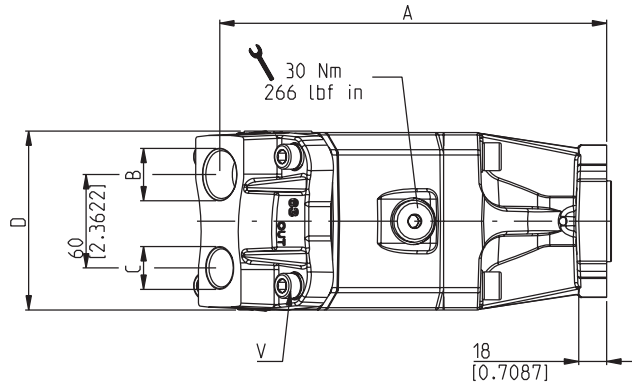
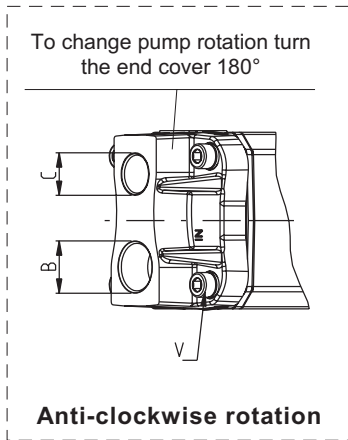

Pump type	V Bolts tightening torque lbf in (Nm)
BAP 32	358 ÷ 438 (45 ±4.5)

01/04.2007

Pump type	A	B (IN)		D	E	F	G	H
		BSPP						
		in (mm)	lbf in (Nm)					
BAP 32•40	9.8031 (249)	G 1 620÷664 (70 ⁺⁵)	G 3/4 797÷841 (90 ⁺⁵)	4.5276 (115)	10.3937 (264)	3.5827 (91)	4.2913 (109)	6.8110 (173)
BAP 32•50								
BAP 32•63								
BAP 32•71								
BAP 32•80								

Rotation: S=anti-clockwise - D=clockwise

How to order

BAP 32•40 S0 - 19 T1 - P GF/GE - N TN

GAS BSPP THREADED PORT CONNECTORS

Inlet

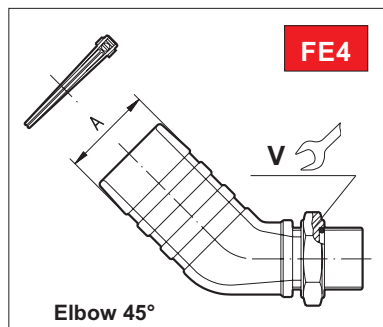

Brass elbow 45°. They are supplied complete with O-Ring and hose clamp.

Connector type	A	V		Pump type
	Tubing nominal size	Chey	lbf in (Nm)	
FE4-GF/N112-N	1" 1/2	41	354 ÷ 443 (45 ±5)	BAP 32
FE4-GF/N200-N	2"	41	354 ÷ 443 (45 ±5)	
FE4-GG/N200-N	2"	50	398 ÷ 487 (50 ±5)	BAP 37
FE4-GG/N212-N	2" 1/2	50	398 ÷ 487 (50 ±5)	

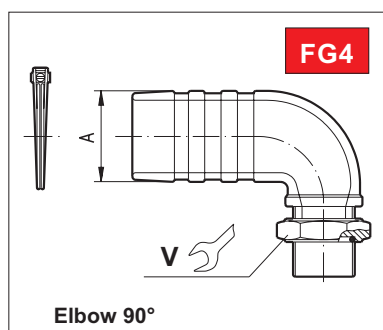

Brass elbow 90°. They are supplied complete with O-Ring and hose clamp.

Connector type	A	V		Pump type
	Tubing nominal size	Chey	lbf in (Nm)	
FG4-GF/N112-N	1" 1/2	41	354 ÷ 443 (45 ±5)	BAP 32
FG4-GF/N134-N	1" 3/4	41	354 ÷ 443 (45 ±5)	
FG4-GF/N200-N	2"	41	354 ÷ 443 (45 ±5)	
FG4-GG/N200-N	2"	50	398 ÷ 487 (50 ±5)	BAP 37

Outlet - max. 5075 psi (350 bar)

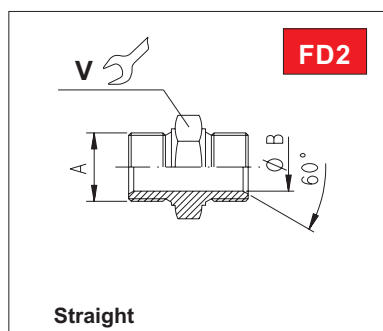

Steel straight port connector

Connector type	A	Ø B	V		Pump type
	Tubing nominal size	in (mm)	Chey	lbf in (Nm)	
FD2-GE/MG34	G 3/4"	0.669 (17)	32	797 (90) [●]	BAP 32
FD2-GF/MG1	G 1"	0.906 (23)	41	1328 (150) [●]	BAP 37

[●] Tightening torque tolerance to be applied to the values shown in the table: +10 %